

P.O. Box 1240
Afton, WY 83110 USA
Tel: 307-885-3151
Fax: 307-885-9674
e-mail: aviat@aviataircraft.com

DATE: 16 September 2010

REVISION: NC

AIRCRAFT MODEL: Pitts S-2C

SUBJECT: Mounting Kit for Composite Spinner

SERIAL NUMBERS AFFECTED: 6074-6088 with Composite Spinner D-7409

Engineering Data is FAA Approved

DESCRIPTION

According to Hartzell Propeller Inc. as of this date the Pitts S-2C equipped with the Hartzell composite spinner (part number D-7409) needs to have the mounting kit A-2476-6 replaced. The new spinner mounting kit number is A-2476-34.

COMPLIANCE

Complete the installation instruction of this service bulletin using appropriate F.A.A. authorized mechanics. Complete and send compliance letter to appropriate addresses.

TABLE OF CONTENTS

Description and Compliance.....1
Table of Contents.....2
Parts List.....3
Installation Instructions.....4
Compliance Letter.....5
Hartzell Installation procedures.....6-7

PARTS LIST

NO. REQ.	CODE NUMBER	KIT NUMBER	DESCRIPTION
1	62553	A-2476-34	Spinner Mounting Kit

INSTALLATION INSTRUCTIONS*

1. Read the attached letter from Hartzell and comply.

For any further question please call Hartzell Product Support: Telephone: 937-942-4200 (option3) Fax: 937-778-4291 E-Mail techsupport@hartzellprop.com.

***NOTE:**

- Only FAA authorized repairmen should perform the following instructions.
- It is the responsibility of owner/operator to have FAA authorized repairmen perform this work.

COMPLIANCE LETTER

This is to certify that I have completed Service Bulletin 35 by installing Hartzell spinner mounting kit A-2476-34 on airplane:

Serial Number _____ Registration Number _____

Model Number _____

Date: _____ Aircraft Hours: _____ Hours

Signed: _____

Return completed letter to:

Engineering
Sky International, Inc.
P.O. Box 1240
Afton, WY 83110
Fax: 307-885-9674

Send copy to:

Federal Aviation Administration
Denver Aircraft Certification Office
Attn: Roger Caldwell
26805 East 68th Avenue, Room 214
Denver, CO 80249-6361
Fax: 303-342-1088



Hartzell Propeller Inc.
One Propeller Place
Piqua, OH 45356-2634 USA
Tel: +1-937-778-4200
Fax: +1-937-778-4271
www.hartzellprop.com

Dear S-2C Aircraft Owner:

It has been brought to Hartzell's attention that some S-2C aircraft owners are operating propellers with composite spinners using a p/n: A-2476-6 spinner mounting kit. The A-2476-6 Spinner Mounting Kit is designed for installation of a metal bulkhead only, and is not intended for use with a composite bulkhead. While this condition presents no airworthiness problems, minor composite bulkhead damage could result from the combination of an A-2476-6 spinner mounting kit and a D-7404 composite bulkhead.

When installing a composite bulkhead, spinner mounting kit part number A-2476-34 is to be used instead. The A-2476-34 mounting kit uses a "top hat" style spacer and different washers. (Metal bulkheads use a straight cylindrical spacer instead.) The "top hat" style spacer is designed to fit inside the bulkhead mounting hole and incorporates a shoulder designed to rest on the forward side of the bulkhead. This "top hat" configuration spacer prevents the bulkhead from being crushed/damaged in the area around the bulkhead mounting bolts (see below).

Complete installation procedures of the correct configuration can be found on pages 3-14 & 3-15 of Hartzell Propeller Owner's Manual 115N (metal blades) or pages 3-12 & 3-13 of Hartzell Propeller Owner's Manual 145 (composite blades), both available at no charge from the Hartzell website (www.hartzellprop.com).

If the incorrect spacer was used on a composite bulkhead, the bulkhead could show visible signs of delamination around the bulkhead mounting hole (see attached illustration). Visible indications include: frayed material, indentations, or crushed material around the bulkhead mounting holes. Scratched paint is not a concern in this inspection.

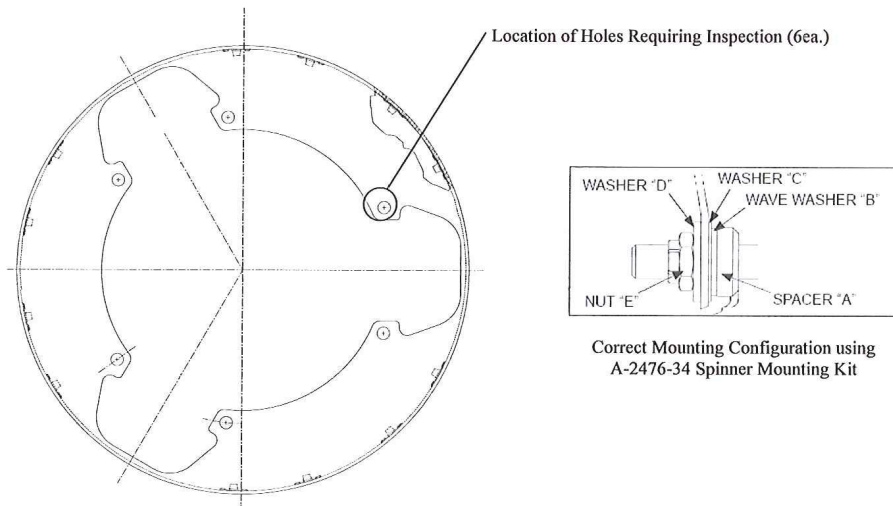

Hartzell is requesting any installation incorrectly using the A-2476-6 Mounting Kit on a composite bulkhead, remove and inspect the bulkhead for damage. If damage as described above is seen, please contact Hartzell Product Support department immediately for damaged bulkhead serviceability, disposition determination, and potential warranty.

Hartzell Product Support can be reached at:

Telephone: 937-942-4200 (option 3)
Telefax: 937-778-4291
E-Mail: techsupport@hartzellprop.com.

Thank you very much for your immediate attention in this matter. Please contact Hartzell with any questions or concerns.

Sincerely,



Michael R. Mayhill
Product Support Manager
Hartzell Propeller Inc.

****IMPORTANT/CONFIDENTIAL** - This communication is for the exclusive and confidential use of the designated recipient(s), and any other use, dissemination, distribution or reproduction of this message is unauthorized and strictly prohibited. If you have received this communication in error, please immediately notify the sender by telephone (001(937) 778-4200), permanently delete the original from any computer and/or system, and destroy any printout of the document. Do not forward this communication to anyone else.