

No: 000295

CHRISTEN INDUSTRIES, INC.  
1048 SANTA ANA VALLEY ROAD  
HOLLISTER, CALIFORNIA 95023  
TELEPHONE: (408) 637-7405

By: FLC Date: 03-14-83 Page: 1 of 3

Send To: 904 FUSELAGE KIT

C \*\* AFFIX LABEL HERE \*\*

U  
S  
TSubject: CHANGE OF CANOPY AFT  
HINGE ATTACHMENT IN  
EAGLE II AIRCRAFT 904 AND  
915 CONSTRUCTION KITS

Eagle II aircraft fuselage structures manufactured prior to January 1983 used a hinge support stud, located behind the right rear seat armrest, which supported the rear hinge of the canopy system. Several aircraft have experienced failure of this stud.

Although flight safety is not affected by failure of the stud, the rear hinge attachment has been redesigned for increased strength and serviceability. All 904 Fuselage Structure Kits and 915 Canopy Kits delivered after January 1983 have been supplied with the redesigned hinge attachment.

Retrofit of the new hinge attachment system to all Eagle II aircraft under construction or completed is highly recommended. Ideally retrofit should be made prior to making the canopy rear hinge installation (Unit D of 915 Kit product manual); however, aircraft can be modified at any stage of construction.

Eagle II builders and owners who prefer to use the original hinge attachment method may do so, but they should be aware that stud breakage may occur in time. Builders who received their 904 Kit prior to January 1983 and their 915 Kit after January 1983 can attach the later hinge on the original support stud (Step D-2 in 915 Kit product manual) if a 50241-001 (MS20364-1064) thin nut is available to hold the hinge bearing on the stud.

The fuselage modification procedure for the new hinge attachment consists of trimming off the original stud and drilling through the stud base to form a support bushing through which a new hinge support bolt can be mounted. A special drill guide and drill are required as listed below. (It is essential that a properly sharpened drill be used to ensure hole straightness, location, and angle.)

Modification of the canopy system consists of simply adding a bolt, castle nut and cotter pin to replace the original thin nut and support stud.

All special tools and parts required for modification of fuselages and canopy systems supplied prior to January 1983 are listed below. The prices for both the drill guide and the drill may be considered as deposits only, since these items may be returned for credit after use.



No: 000295

\*\* AFFIX LABEL HERE \*\*

By: FLC Date: 03-14-83 Page: 3 of 3



moderate drag but with no axial play.

8. Secure the castle nut in its adjusted position with the 50131-001 cotter pin. Clinch the prongs of the cotter pin if the aircraft has been completed (through 923 Kit), or spread the prongs only slightly to keep the pin in position, but to allow removal later during remaining construction.
9. Reinstall all rear seat and canopy components as appropriate.

Enclosure:

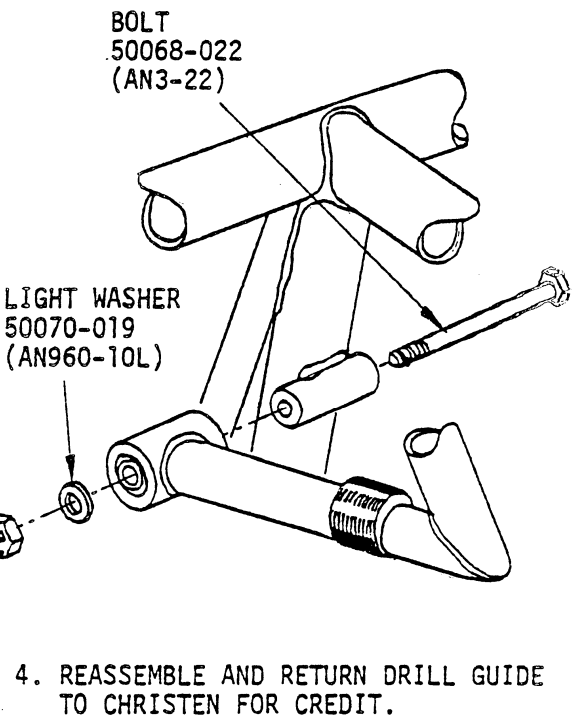
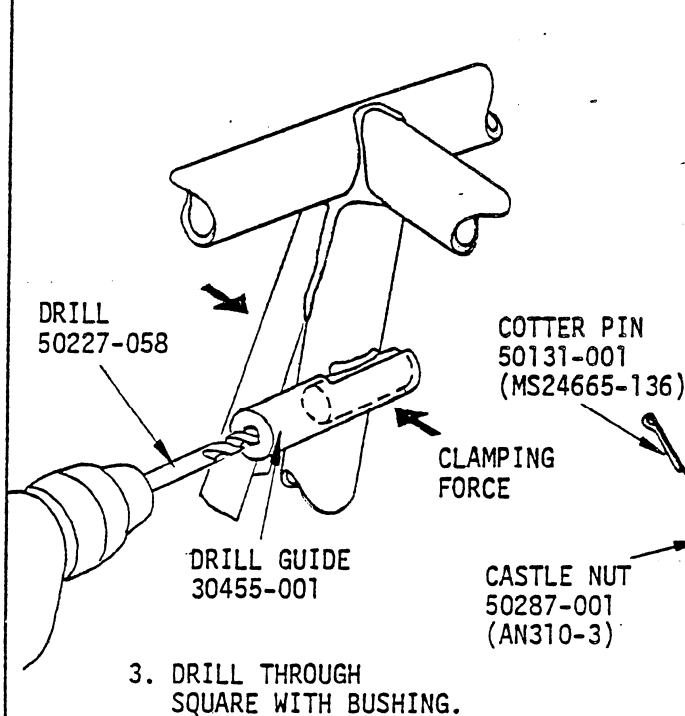
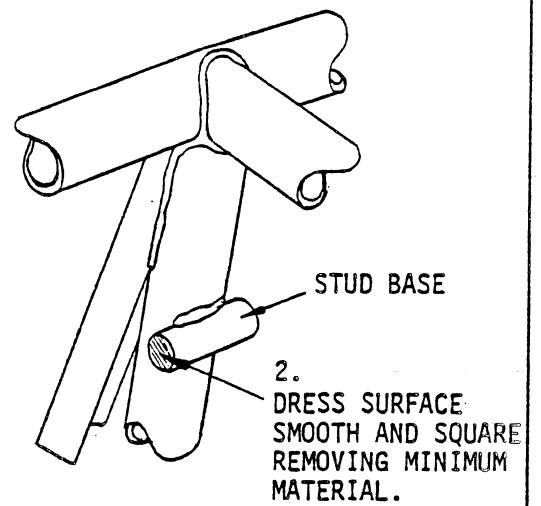
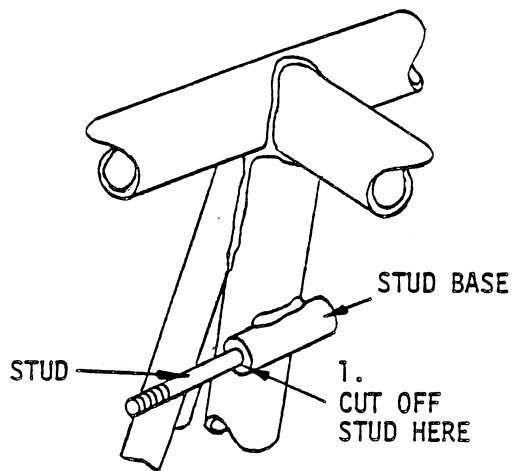
ENGINEERING SKETCH X-90136



<b>UNLESS OTHERWISE SPECIFIED:</b>  TOLERANCES: FRAC. $\pm$ 1/64 DEC. XXX $\pm$ .005 ANGLES $\pm$ 0° 30'  DIMENSIONS IN INCHES  DO NOT SCALE DRAWING	MATERIAL AND CONDITION NOTED			<b>CHRISTEN</b>  <small>CHRISTEN INDUSTRIES HOLLISTER, CALIFORNIA</small>		
	FINISH NONE			<b>ENGINEERING SKETCH</b>		
	DRAWN BY I. CLEDE	DATE 8-21-81	PROJECT EAGLE II AIRCRAFT	TITLE AFT CANOPY PIVOT REPAIR		
	APPROVED BY 	DATE 8-22-82		CODE PA	NO. X-90136	ISSUE A